

REHABILITATION - AMENAGEMENT DU PONT SUR LA VIEILLE LOIRE A DECIZE



Etudes préalables

Inspection subaquatique – Plans de repérage des désordres

Référence						
ENTITE	PHASE	THEME	TYPE	NUM	IND	
COB	EP1	OUV	PLN	0106	A00	



Note générale : Nombreuses épaufrures et végétation arbustive parasite au niveau des couronnements.
 Tympan amont et aval en état médiocre, nombreuses épaufrures, pierres manquantes, et zones d'érosion.
 Voûte partiellement épaufrée et fracturée au niveau des bandeaux amont et aval. Voir photos

ELEVATION SCHEMATIQUE AVAL

Légende
 Bathymétrie 2020
 Bathymétrie NGF 2020

échelle 1/200

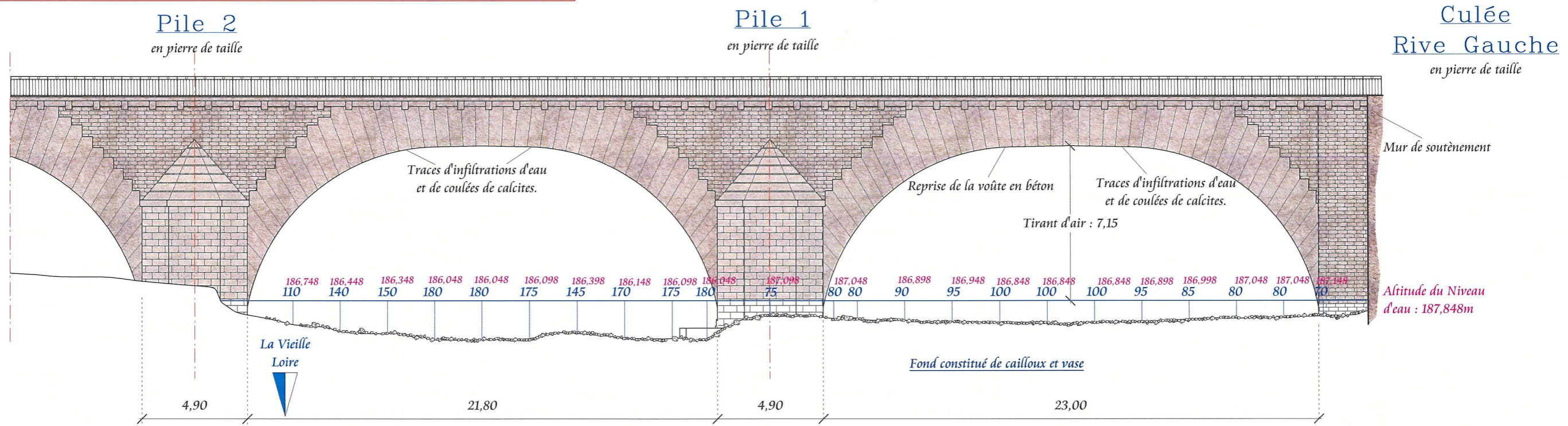

Vue amont
 -Photo 1-



Ouvrage : PONT DE LA VIEILLE LOIRE
 Identifiant : 1.095.5
 Voie portée : RD978A - PR38+120
 Franchissement : LA VIEILLE LOIRE

INGÉROP
 Inventons demain
 Campagne 2020

Ech. 1/200
 Page 01

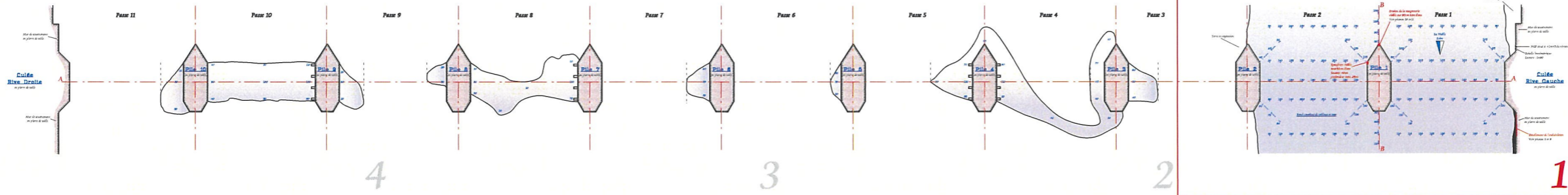

Note générale : Nombreuses épaufrures et végétation arbustive paraïste au niveau des couronnements.
 Tympan amont et aval en état médiocre, nombreuses épaufrures, pierres manquantes, et zones d'érosion.
 Voûte partiellement épaufrée et fracturée au niveau des bandeaux amont et aval. Voir photos

VUE EN PLAN ET BATHYMETRIE

échelle 1/200

Légende
 Bathymétrie 2020
 Bathymétrie NGF 2020

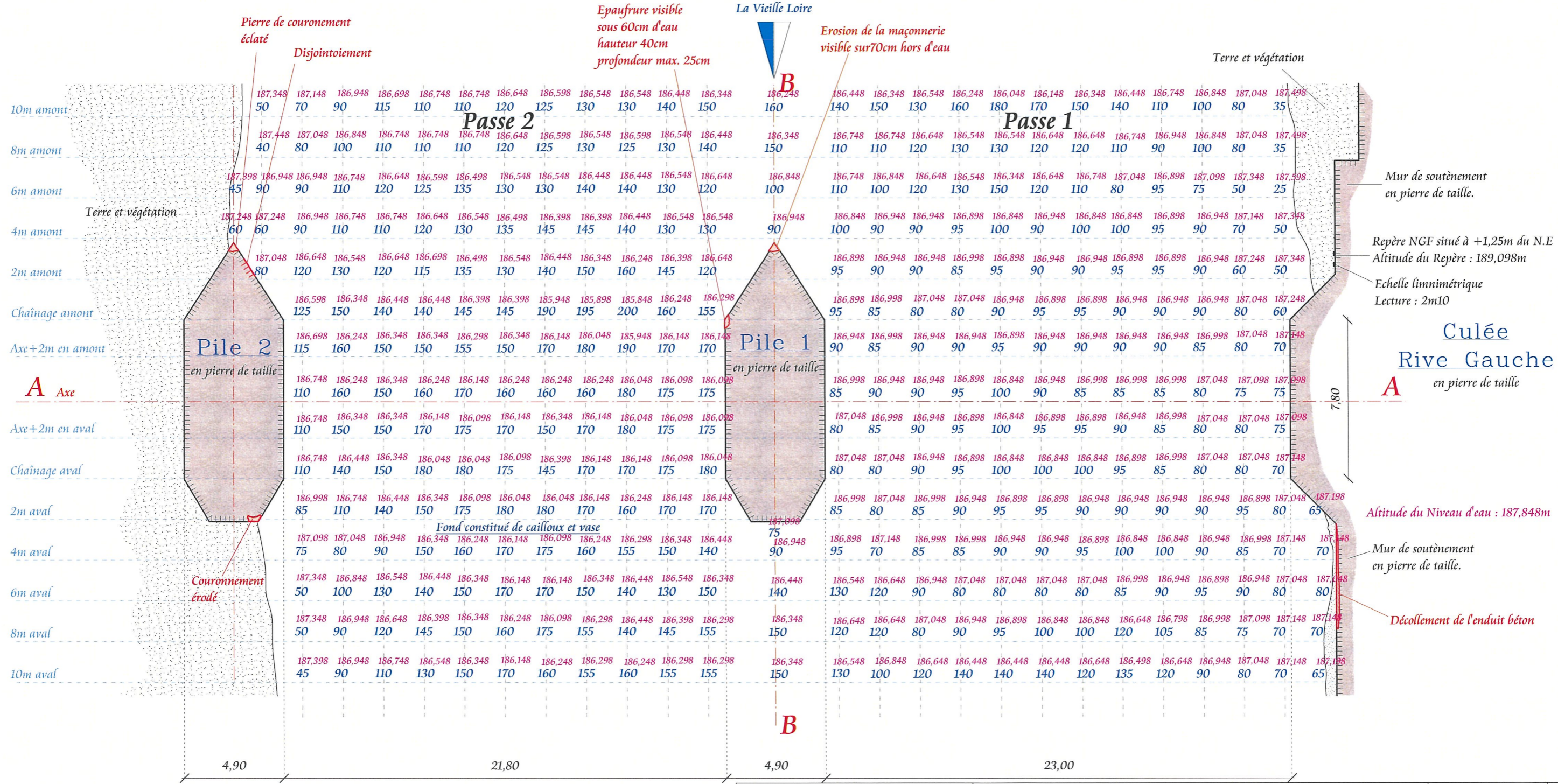

Ouvrage : PONT DE LA VIEILLE LOIRE
 Identifiant : 1.095.5
 Voie portée : RD978A - PR38+120
 Franchissement : LA VIEILLE LOIRE



Ech. 1/200
 Page 02

Campagne 2020

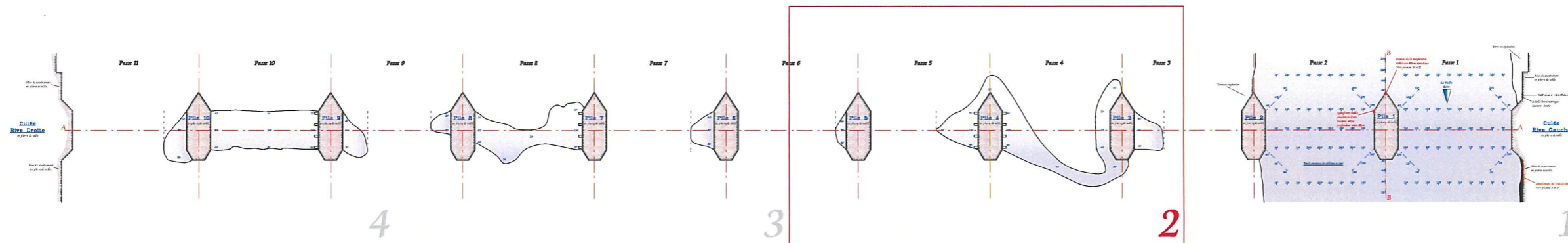

VUE EN PLAN ET BATHYMETRIE

échelle 1/200

Passé 6

Passé 5

Passé 4

Passé 3

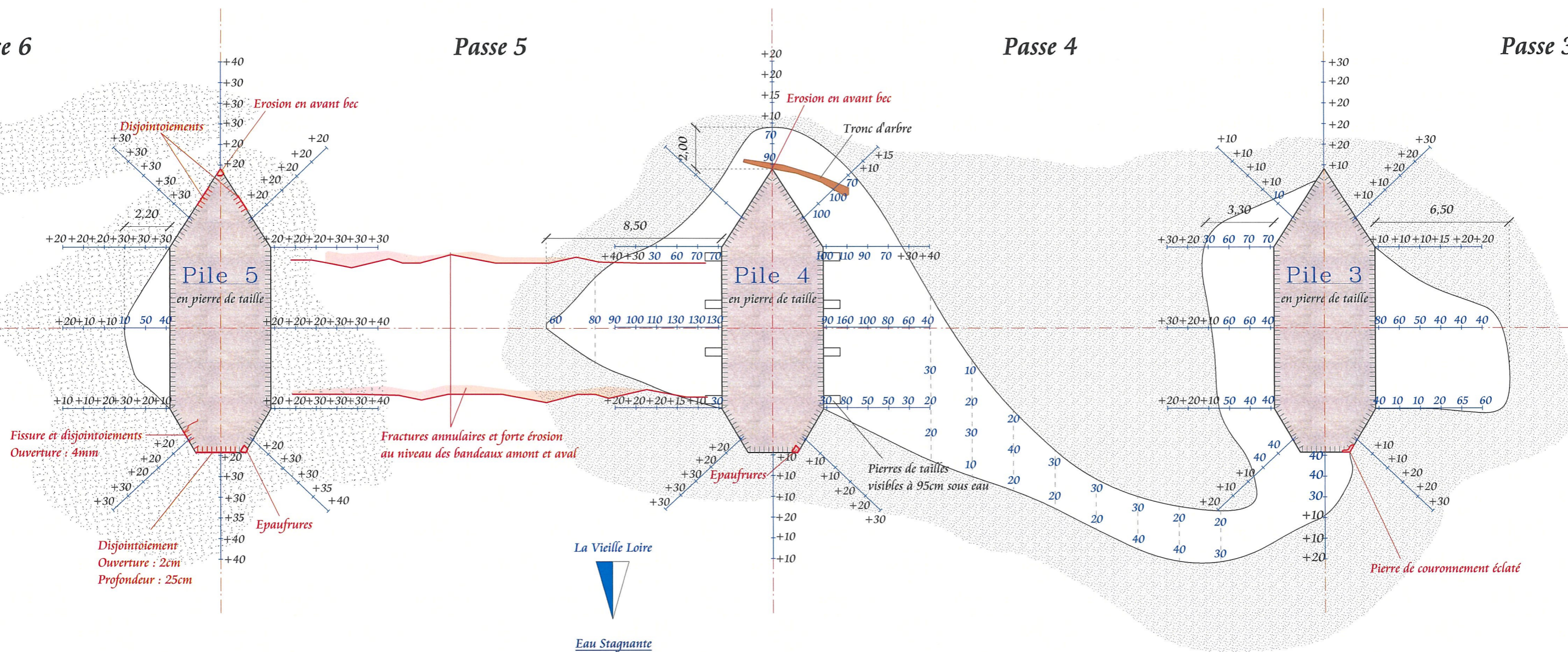

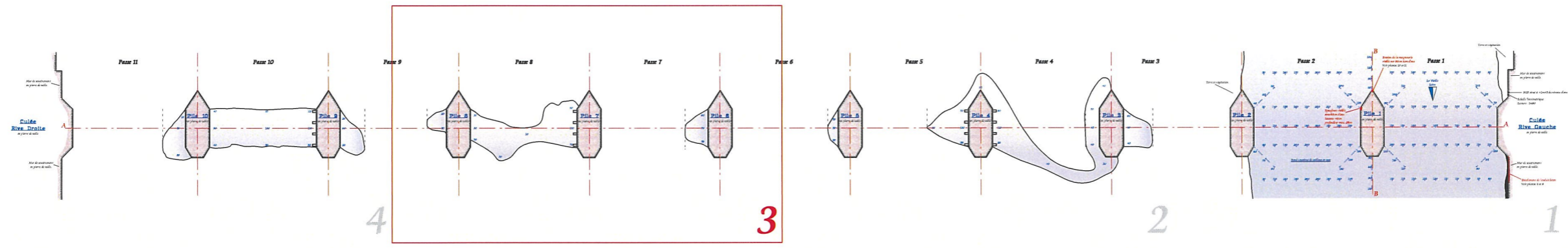

VUE EN PLAN ET BATHYMETRIE

échelle 1/200

Passe 9

Passe 8

Passe 7

Passe 6

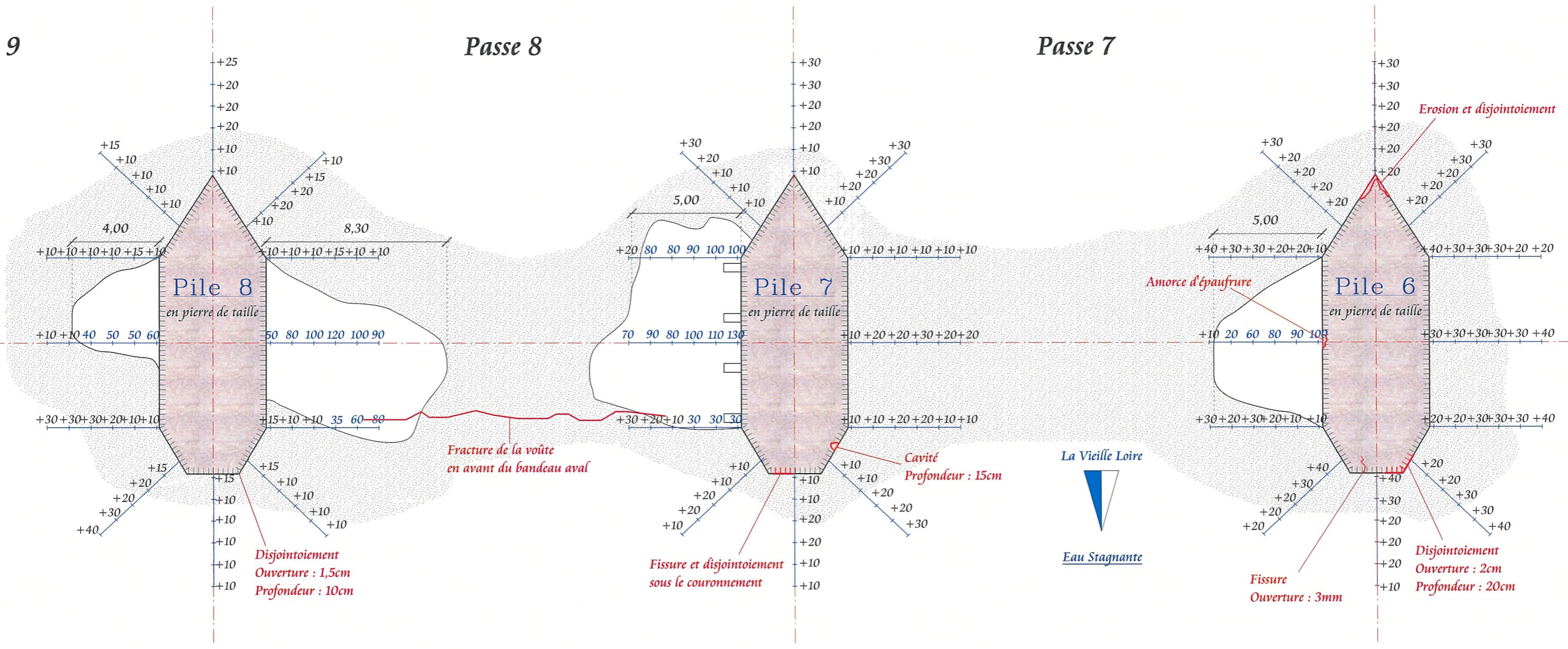

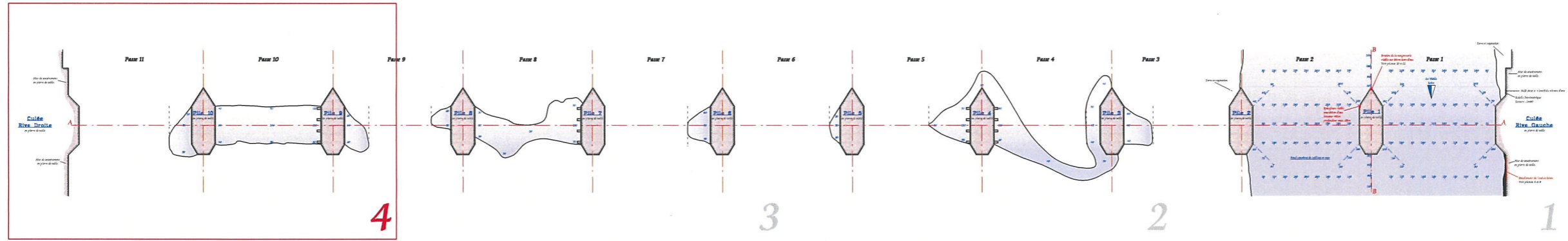

VUE EN PLAN ET BATHYMETRIE

échelle 1/200

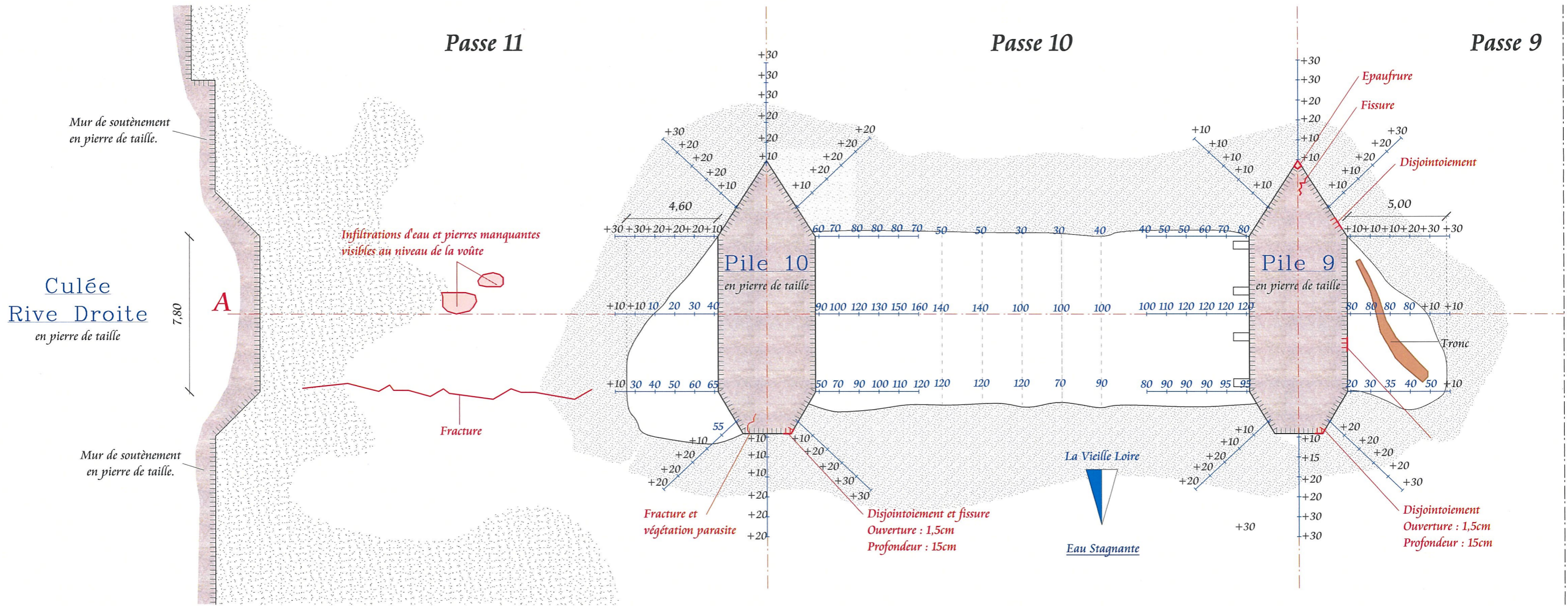

VUE EN PLAN ET BATHYMETRIE DE LA CULÉE RIVE GAUCHE

échelle 1/125

Légende
Bathymétrie 2020
Bathymétrie NGF 2020

Repère NGF situé à +1,25m du N.E Altitude du Niveau d'eau : 187,848m
Altitude du repère : 189,098m

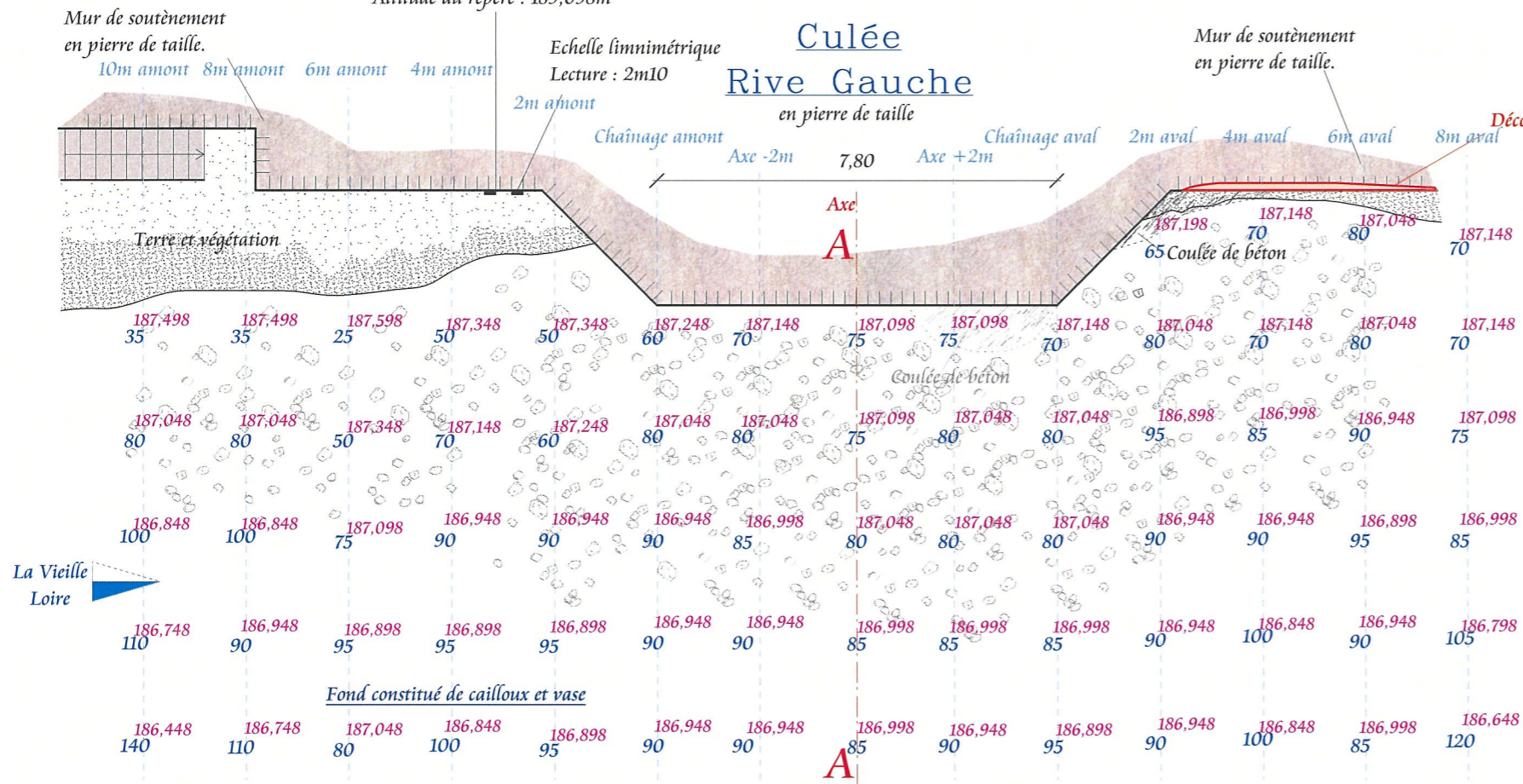

COUPE A-A échelle 1/125

Légende
Bathymétrie 2020
Bathymétrie NGF 2020

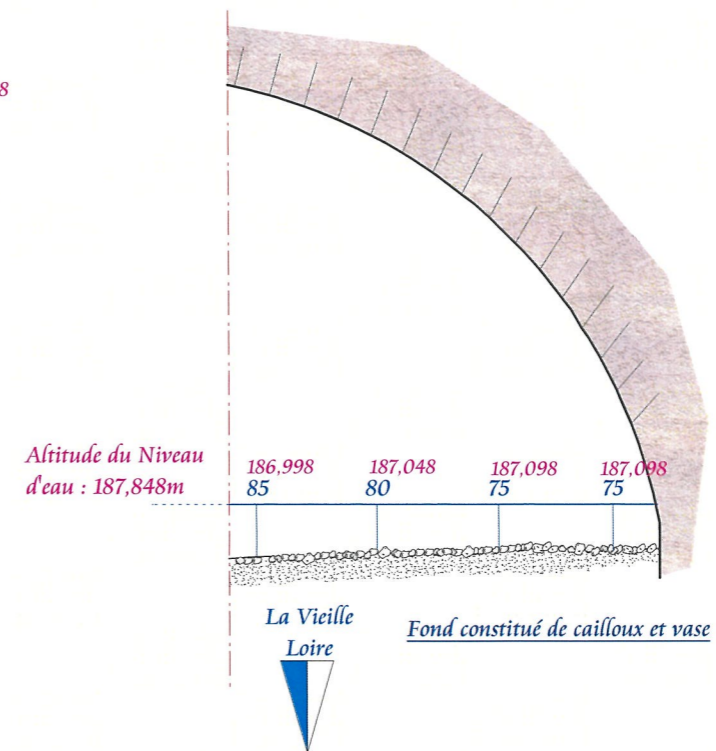

VUE EN PLAN ET BATHYMETRIE DE LA PILE 1

échelle 1/125

Légende
Bathymétrie 2020
Bathymétrie NGF 2020

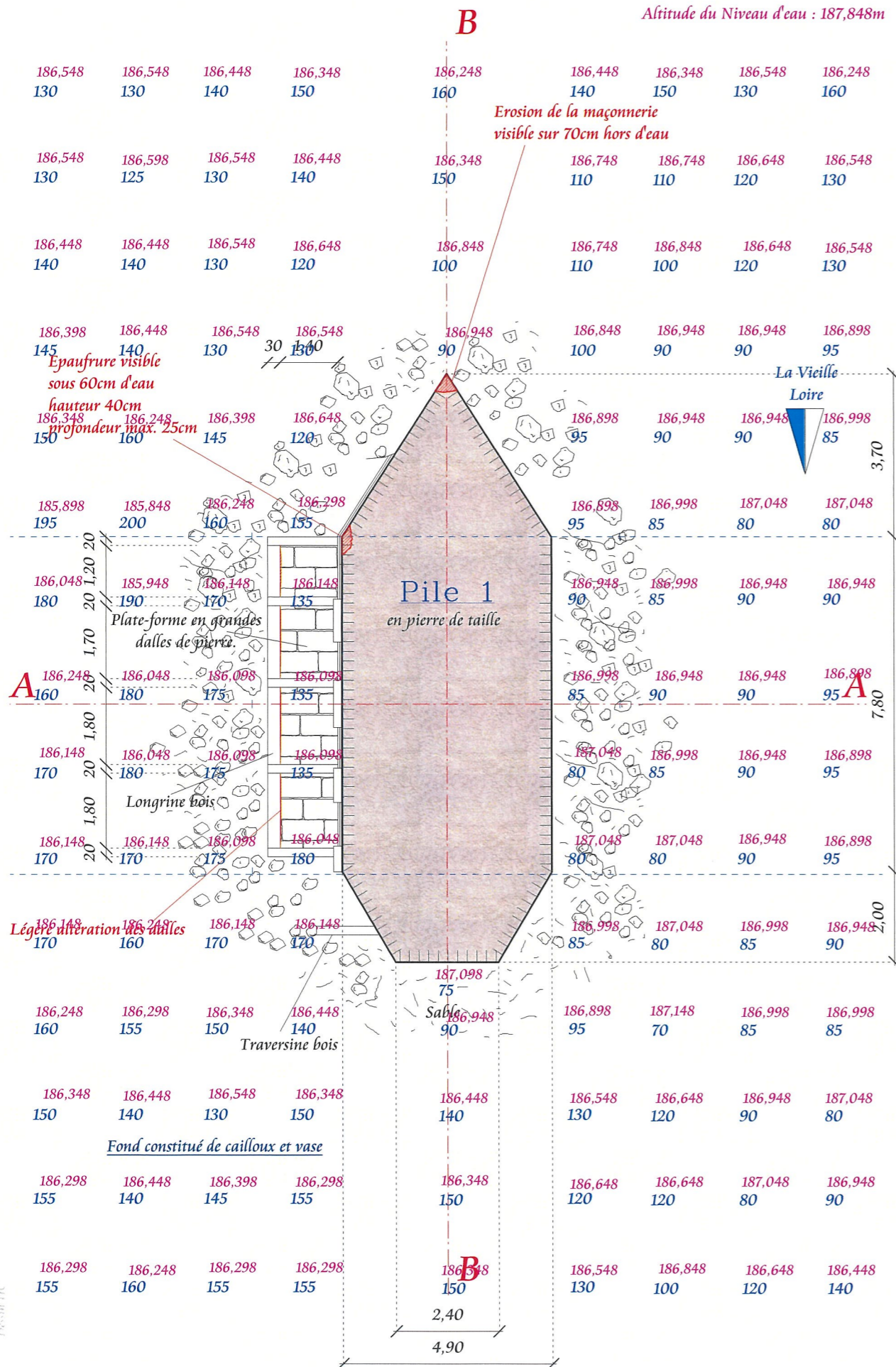

COUPE B-B échelle 1/125

Légende
Bathymétrie 2020
Bathymétrie NGF 2020

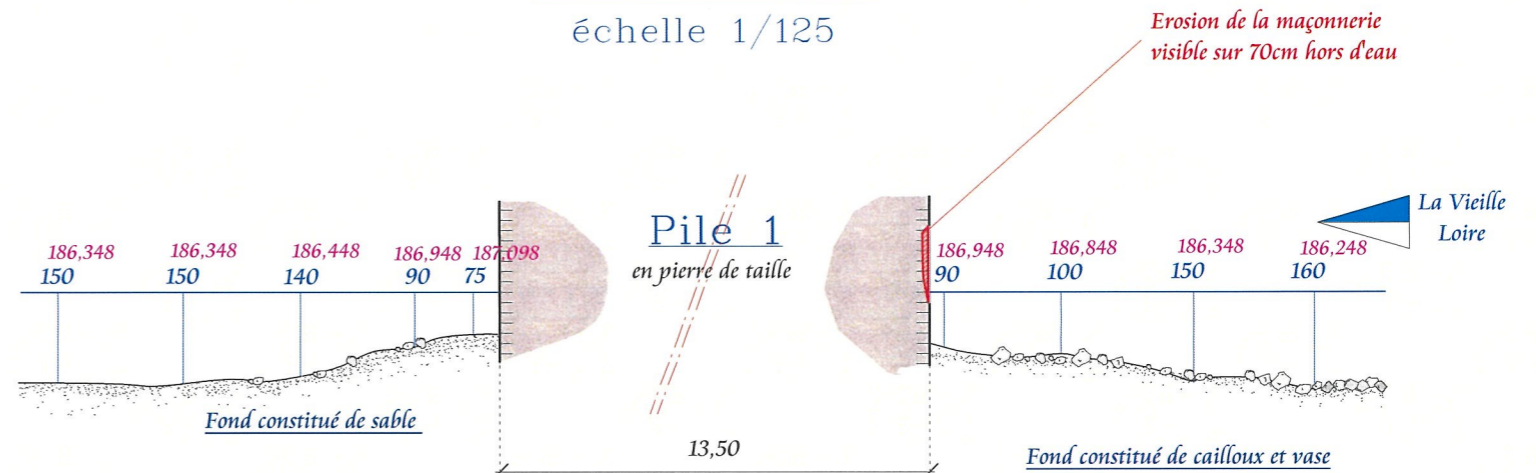

COUPE A-A échelle 1/125

Légende
Bathymétrie 2020
Bathymétrie NGF 2020

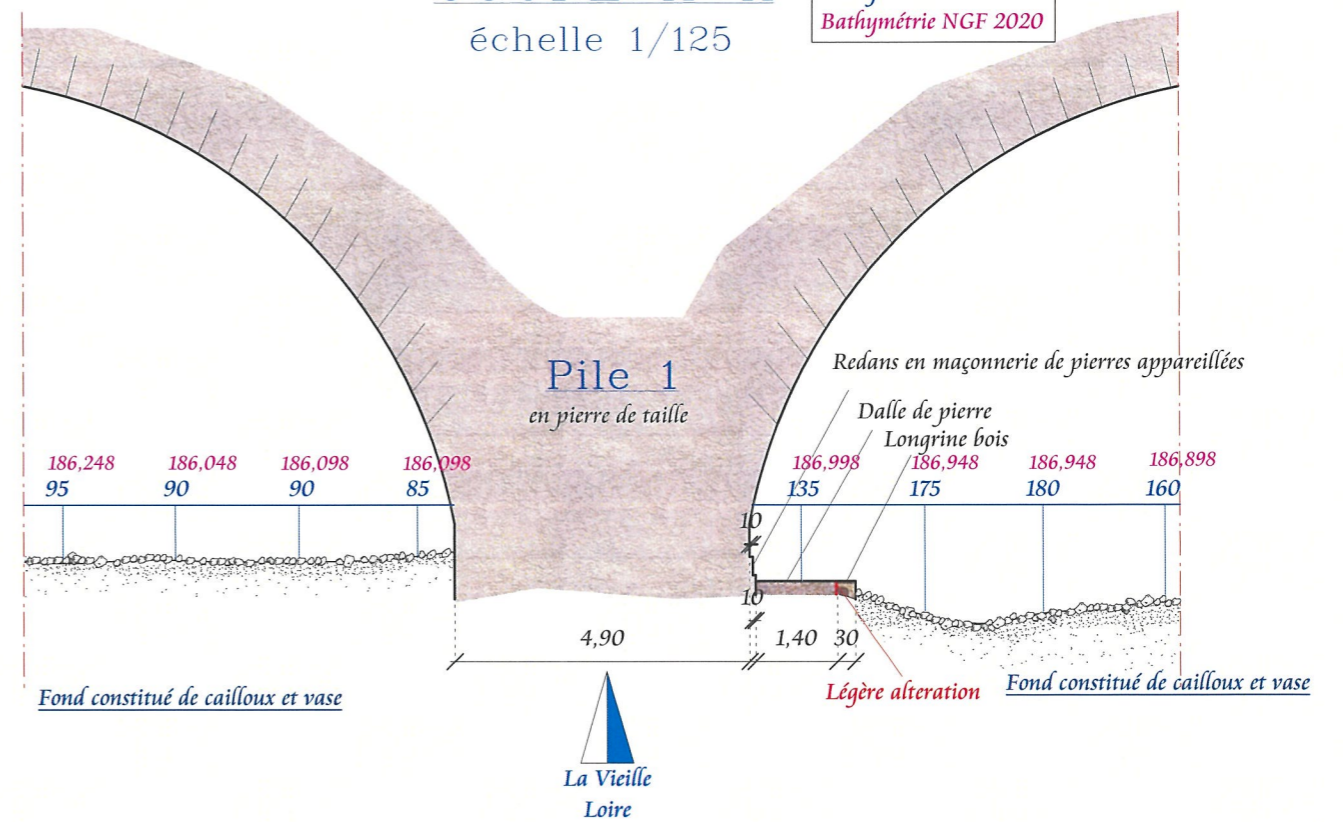



Mur retour aval de la culée rive gauche
 -Photo 2-



Mur retour amont de la culée rive gauche
Epaufrure
 -Photo 3-



Culée rive gauche
 -Photo 4-



Culée rive gauche
Vue sous-marine
 -Photo 5-



Avant bec Pile 1
Végétation parasite au niveau du couronnement
 -Photo 6-



Avant bec Pile 1
Epaufrement et érosion
 -Photo 7-

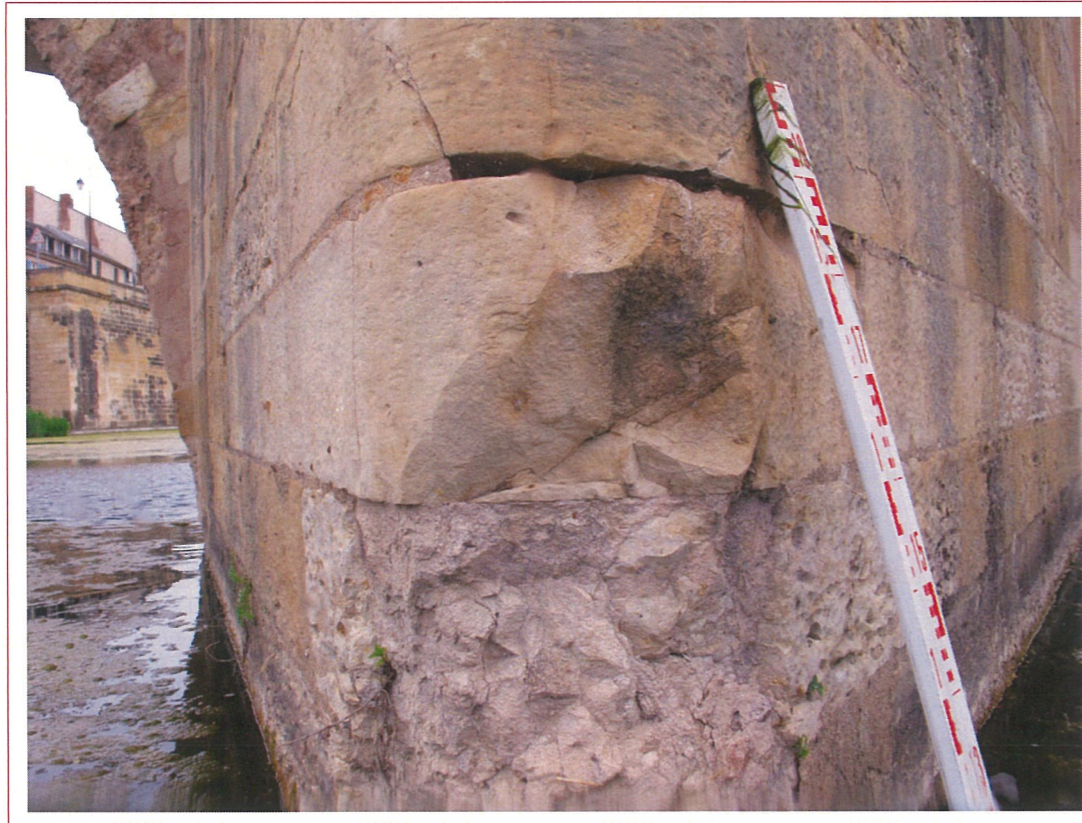

Avant bec Pile 1
Epaufrement et érosion
 -Photo 8-



Avant bec Pile 1
Vue sous-marine
 -Photo 9-



*Face gauche Pile 1
-Photo 10-*



*Arrière bec Pile 1
Végétation parasite sur le couronnement
-Photo 11-*



*Face droite Pile 1
-Photo 12-*



*Intrados passe 2
-Photo 13-*



Avant bec Pile 2
Disjointement et pierre de couronnement éclatée
 -Photo 14-



Face gauche Pile 2
 -Photo 15-



Arrière bec pile 2
Végétation parasite
 -Photo 16-



Face droite Pile 2
 -Photo 17-



Tympan amont Passe 3
Erosion du bandeau
 -Photo 18-



Avant bec Pile 3
 -Photo 19-



Face gauche Pile 3
 -Photo 20-

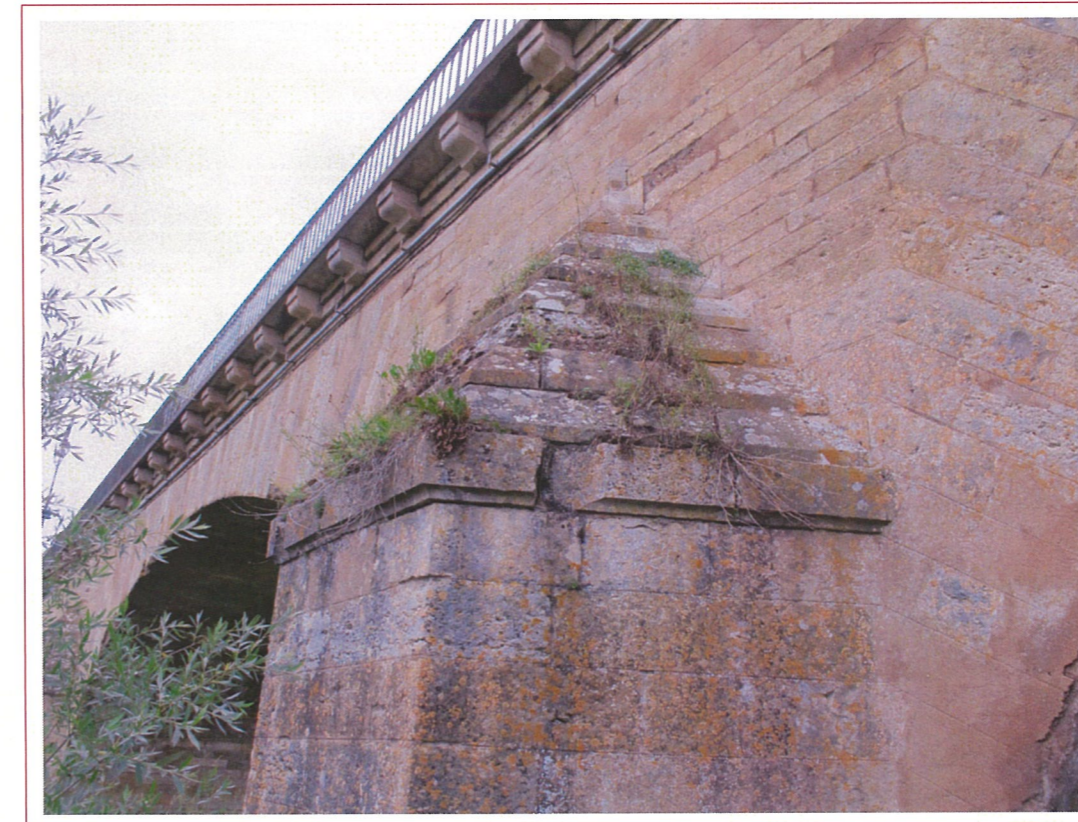

Arrière bec Pile 3
Epaufure
 -Photo 21-



Face droite Pile 3
-Photo 22-



Face droite Pile 3 (Amont)
Erosion du bandeau
-Photo 23-



Tympan amont en passe 4
Erosion du bandeau
-Photo 24-



Face droite Pile 3
 -Photo 22-



Face droite Pile 3 (Amont)
Erosion du bandeau
 -Photo 23-



Avant bec Pile 4
Erosion ; Végétation parasite sur le couronnement
 -Photo 24-



Avant bec Pile 4
Tronc d'arbre
 -Photo 25-



Face gauche Pile 4
 -Photo 26-



Arrière bec Pile 4
 -Photo 27-



Avant bec Pile 4
Erosion ; Végétation parasite sur le couronnement
 -Photo 24-



Avant bec Pile 4
Tronc d'arbre
 -Photo 25-



Face gauche Pile 4
 -Photo 26-



Arrière bec Pile 4
Epaufrure
 -Photo 27-



Tympan amont passe 5
Epaufures du bandeau
 -Photo 28-



Fracture annulaire au niveau du bandeau amont
 -Photo 29-



Tympan aval
Epaufures du bandeau
 -Photo 30-



Avant bec Pile 5
Erosion
 -Photo 31-



Face gauche Pile 5
Fracture annulaire au niveau du bandeau amont
 -Photo 32-



Arrière bec Pile 5
Epaufures et disjointoiements
 -Photo 33-



Arrière bec Pile 5
Disjointoiement
 -Photo 34-



Arrière bec Pile 5
Disjointoiement
 -Photo 35-



Face droite Pile 5
 -Photo 36-



Tympan amont en passe 5
Epaufures du bandeau
 -Photo 37-



Avant bec Pile 6
Disjointoiement
 -Photo 38-



Face gauche Pile 6
 -Photo 39-



Tympan aval en passe 5
Epaufures du bandeau
 -Photo 40-



Arrière bec Pile 6
Epaufures du tympan
 -Photo 41-



*Face droite Pile 6
-Photo 42-*



*Face droite Pile 6
-Photo 43-*



*Avant bec Pile 7
-Photo 44-*



*Face gauche Pile 7
-Photo 45-*



*Tympan aval Passe 7
Epaufures du bandeau
-Photo 46-*



*Arrière bec Pile 7
-Photo 47-*



Face droite Pile 7
 -Photo 48-



Face droite Pile 7
 -Photo 49-



Avant bec Pile 8
Erosion et végétation parasite
 -Photo 50-



Face gauche Pile 8
Erosion du bandeau amont
 -Photo 51-

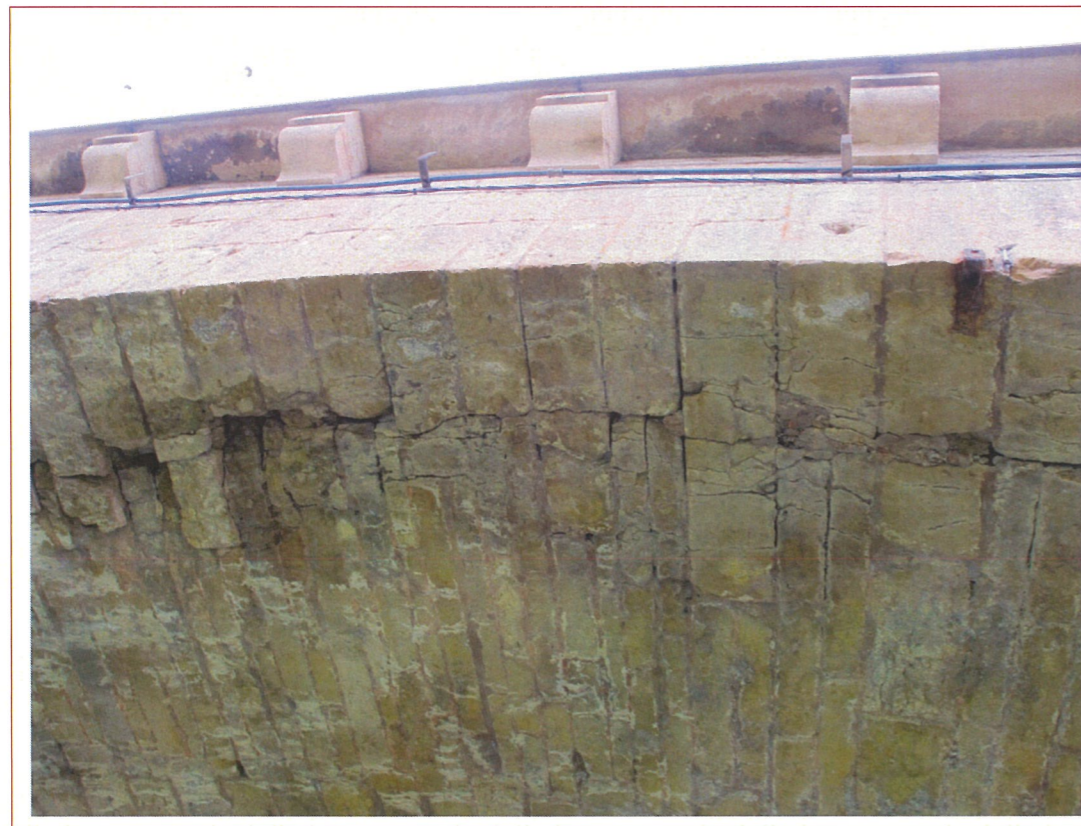

Vue de la voûte en aval de la passe 8
Fracture annulaire et érosion
 -Photo 52-



Vue de la voûte en aval de la passe 8
Fracture annulaire et érosion
 -Photo 53-



Arrière bec Pile 8
Végétation parasite sur le couronnement
 -Photo 54-



Face droite Pile 8
 -Photo 55-



Avant bec Pile 9
-Photo 56-



Face gauche Pile 9
-Photo 57-



Face gauche Pile 9
-Photo 58-



Arrière bec Pile 9
-Photo 59-



*Face droite Pile 9
-Photo 60-*



*Face droite Pile 9
-Photo 61-*



Avant bec Pile 10
-Photo 62-



Face gauche Pile 10
-Photo 63-



Tympan aval de la passe 11
Epaufures du bandeaux
-Photo 64-



Arrière bec Pile 10
Végétation parasite sur le couronnement
-Photo 65-



Face gauche Pile 10
-Photo 66-



Intrados en passe 11
Pierres manquantes
-Photo 67-



Bandeau aval en passe 11
Erosion et fissures
-Photo 68-



Tympan aval droit
Epaufrures du bandeau
-Photo 69-



Mur retour amont de la culée rive droite
 -Photo 70-



Culée rive droite
 -Photo 71-



Mur retour aval de la culée rive droite
 -Photo 72-



Vue aval
 -Photo 73-